

EquityClear

LCH ERA TIP

LCH EQUITY RISK ANALYSIS TECHNICAL INFORMATION PACK

LCH The Markets'
Partner



Table of Contents

1. INTRODUCTION.....	3
1.1 BACKGROUND.....	3
1.2 PURPOSE	3
1.3 DOCUMENT OVERVIEW.....	3
1.4 GLOSSARY OF TERMS	4
2. LCH ERA MARGIN OVERVIEW.....	5
2.1 VARIATION MARGIN.....	5
2.2 INITIAL MARGIN.....	5
2.3 WRONG WAY RISK MARGIN.....	5
2.4 LIQUIDITY AND CONCENTRATION RISK MARGIN.....	5
3. LCH ERA INPUT DATA.....	7
3.1 POSITION.....	8
3.2 PRICE.....	9
3.3 EXCHANGE RATE.....	9
3.4 EQUITY.....	11
3.5 BUCKET.....	11
3.6 GLOBAL.....	13
3.7 DAILY VOLUME.....	13
3.8 LCRM.....	13
3.9 LCRM BUCKET.....	13
3.10 ACCOUNT	14
4. LCH ERA CALCULATION DETAIL.....	15
4.1 ACCOUNTS & POSITIONS	15
4.2 VARIATION MARGIN.....	16
4.3 INITIAL MARGIN	19
4.4 WRONG WAY RISK MARGIN.....	24
4.5 LIQUIDITY AND CONCENTRATION RISK MARGIN.....	24
4.6 ROUNDING RULES.....	28
5. WORKED EXAMPLES	29
5.1 IM & VM FOR END-OF-DAY 22/5/2001	29
5.2 IM & VM FOR INTRA-DAY 23/5/2001	35
5.3 LIQUIDITY & CONCENTRATION MARGIN – OSA ONLY.....	41
5.4 LIQUIDITY & CONCENTRATION MARGIN – OSA AND TWO ISAs	42
6. EQUITYCLEAR SERVICE – ERA IMPLEMENTATION.....	43
7. EXAMPLE PARAMETER FILES	44
7.1 IM & VM FOR END-OF-DAY 22/5/2001	44
7.2 IM & VM FOR INTRA-DAY 23/5/2001	46

The copyright in this work is vested in LCH.Clearnet Ltd and is issued in confidence for the purpose for which it is supplied. It must not be reproduced in whole or in part or used for tendering or manufacturing purposes except under an agreement or with the consent in writing of LCH.Clearnet Ltd and then only on the condition that this notice is included in any such reproduction. No information as to the contents or the subject matter of this document or any part thereof arising directly or indirectly there from shall be given orally or in writing or communicated in any manner whatsoever to any third party being an individual firm or employee thereof without the prior consent in writing of LCH.Clearnet Ltd. © 2018 LCH.Clearnet Ltd.

1. Introduction

1.1 Background

LCH.Clearnet Ltd (LCH) uses the LCH ERA (Equity Risk Analysis) algorithm for the calculation of margin of cash equities and equivalent linear instrument positions held in its EquityClear service.

The LCH ERA algorithm was developed by LCH to calculate initial margin (IM) and variation margin (VM) after discussions with a member advisory group late in 1999 and was subsequently approved by the LCH Risk Committee.

Subsequently, and in accordance with the European Market Infrastructure Regulation (EMIR) requirements, wrong way risk margin (WWRM) and liquidity & concentration risk margin (LCRM) have been added to the margin calculation.

1.2 Purpose

This document is the Technical Information Pack (TIP) for LCH ERA. It is primarily targeted at technical developers who may be charged with the development of a system to implement LCH ERA, and is also targeted at their commissioning risk management department. Implementing LCH ERA would enable LCH members to reconcile their margins as calculated by LCH or to pass on margin to clients using the same method.

This technical specification provides full details of the algorithm and the required input data to implement LCH ERA.

1.3 Document Overview

LCH ERA Margin Overview	A description of the four margin types.
LCH ERA Input Data	A description of each set of input data required.
LCH ERA Calculation Detail	A step by step guide through the calculation of the margins.
LCH ERA Worked Examples	Worked examples to clarify understanding and potentially use to test developments of the algorithms.
EquityClear Service - ERA Implementation	A description of what EquityClear produces for members with regards to input files and reports.

1.4 Glossary of Terms

Account	The aggregation level to which margin is calculated. This is the financial account for LCH or an NCM account for a GCM.
Central Securities Depository (CSD)	An organisation where equity settlement takes place (e.g. Euroclear UK & I (EUI) in the UK).
CFD	Contract For Difference. These are open ended contracts which track the value of a reference instrument.
EMIR	European Market Infrastructure Regulation
Financial account	An LCH member's chosen mnemonic sub-account (e.g. for member mnemonic ABC's house account).
General Clearing Member (GCM)	A GCM is an LCH member who can clear equity business for NCMs, as well as themselves and their clients.
ISD	The intended settlement date of an equity trade.
ISIN	International Security Identification Number
LCH	LCH.Clearnet Ltd
LCH ERA	LCH's Equity Risk Analysis algorithm defined by this document.
Margin run	A full execution of LCH ERA initiated at a point in time.
Member mnemonic	A three letter code used by LCH to identify an LCH member. (N.B. an LCH member can have more than one mnemonic.)
Non-Clearing Participant (NCP)	A trading party on a trading venue who is clearing their business through a GCM.
Positions (open positions)	The term position and open position are used synonymously to mean all unsettled trades (or some netting of those trades) to which LCH is central counterparty.
PPS	Protected Payments System. An assured payments system through which LCH can call margin and other cash payments from a member's account in participating banks. It is like a direct debit facility.
TIP	Technical Information Pack.

2. LCH ERA Margin Overview

This section defines the terms variation margin, initial margin, wrong way risk margin and liquidity & concentration risk margin in the context of LCH ERA.

2.1 Variation Margin

Variation margin (VM) is the current unrealised net profit or loss of a position.

Losses (debit variation margin) must be covered by appropriate collateral. Profits (credit variation margin) can be used to offset other debits as allowed by LCH's Risk Department. A particular restriction of the use of credit variation margin is enshrined in the LCH ERA algorithm and relates to the uncertainty LCH has on realising such assets, as it does not have control of settlement.

The variation margin for physically settled securities is the difference between the current value of the position and the settlement value of that position.

CFD positions are marked-to-market against closing prices at end-of-day and the resulting profit/loss is realised by cash settlement for next day value via PPS. This is done before the end-of-day margin run. It is therefore important to note that mark-to-market settlement is different and distinct from variation margin in the context of EquityClear, with end-of-day variation margin being effectively zero.

The intra-day variation margin for a CFD position is the difference between the current value of the position and the net of the previous day's mark-to-market carry forward value and the current days traded value.

The variation margin for cash only positions is the full value of the position.

2.2 Initial Margin

Initial margin (IM) is the primary component of LCH's estimate of the inherent market risk of a portfolio of open positions, designed to cover LCH for the market risk when closing out a member's position following their default. It is calculated separately from wrong way risk margin and liquidity and concentration risk margin.

LCH ERA uses two methods to calculate initial margin.

The 'portfolio method' is designed to take into account any inherent correlation in the prices of equities to fairly reflect the market risk. This is achieved by calculating an initial margin for a group of instruments of like characteristics using their historical prices. Each such grouping of instruments is referred to as a 'bucket' by LCH in relation to LCH ERA.

Where an appropriate price history for an instrument is not available the initial margin for its position is calculated using the alternate 'flat rate method'.

2.3 Wrong Way Risk Margin

Long positions held by a member in their own company are said to have wrong way risk as the default of the member would substantially impact the risk of the position. These positions carry a wrong way risk margin (WWRM) of 100% of their current value. The positions are then excluded from the initial margin and liquidity & concentration risk margin calculations.

2.4 Liquidity and Concentration Risk Margin

Liquidity and Concentration Risk Margin (LCRM) is margin additional to the initial margin, where the size of the position is such that the expected close out period for the position is greater than the standard close out period assumed in the initial margin calculation.

3. Currency of Risk

This section explains the correct usage of the input files to adjust for the individual member's currency of risk.

3.1 Price

The member should select the correct input file aligned to their product and Currency of Risk as confirmed by LCH Collateral Operations;

- For GBP select 'Price.csv'
- For currency XXX select 'PriceXXX.csv' e.g. for EUR select 'PriceEUR.csv'

3.2 Bucket

Members should update the 'Currency' field in the Bucket file to reflect their Currency of Risk

3.3 Global

Members should update the 'LCH base currency' field in the Global file to reflect their Currency of Risk

4. LCH ERA Input Data

ERA calculates margins from three types of input data, positions, prices and risk parameters.

This section defines the dataset structures used by the ERA algorithm. These definitions are used to describe in detail the ERA calculations in the following section.

The following convention is used when referring to a field in a dataset.

- 'dataset name: field name', e.g. 'position: Net quantity'

The table below describes the data types used in the input dataset definitions that follow.

Data Type	String Length	Description	Example
Char(n)	n characters	Exactly 'n' text characters.	GBP
Varchar(n)	0 to n characters	From 0 to 'n' characters.	PORTFOLIO1 FLAT5
Date	8 to 10 characters	UK date format (d/m/yyyy). No leading zero for day or month.	4/3/2008 30/11/2008
Integer	1 to 10 characters for positive numbers 1 to 11 characters for negative numbers	Leading sign used for negative numbers. Range -2147483648 to 2147483647.	1234567 -1234567890
Numeric(n dp)	1 to 18 characters including decimal point and sign for negative numbers	Leading '-' sign used for negative numbers. All numeric values will be rounded to the specified number of decimal places (n dp). Trailing zeros to the right of the decimal point are dropped.	1.35 210 -13.456 -23456.900001
Boolean	4 or 5 characters	Will be either TRUE or FALSE.	TRUE FALSE

4.1 Position

Field	Data Type	Description
Account	Varchar(11).	The 'margin account' or 'position account' to which the algorithm is to be applied. See section 4.1.
ISIN	Varchar(12)	This is the ISIN code of the instrument. Set to CASH for cash only deliveries.
Currency	Char(3)	This is the ISO code of the currency.
Net quantity	Integer	Either the net unsettled number of cash equities or the number of CFDs in the CFD position. Positive values indicate the member is long, negative values indicate the member is short.
Net consideration	Numeric(2*) (* is currency dependent - 2 for GBP and EUR)	For cash equity open positions this is the net unsettled cash payment. Positive values indicate the member is long cash, negative values indicate the member is short cash. For a net DvP position the quantity and consideration will be of opposite sign. For CFD positions this is the value of the position <u>multiplied by -1 (i.e. negated)</u> . By adjusting the value, which is of the same sign as the quantity, to its negative as a 'consideration', the positions as reported produce the correct margin results when processed by the ERA margin algorithm.
ISD	Date	The intended settlement date of the position. For CFD positions this has no business meaning but will be set to 31/12/9999 so that ERA produces correct variation margin results.

4.1.1 CFD positions

CFD positions need to be created in line with the cash equity convention for the correct results to be generated.

Although it has no business meaning the intended settlement date needs to be set beyond the CVM date (as defined later). Within EquityClear and on the relevant EquityClear member reports this is set to 31/12/9999.

The consideration of a CFD position must be set with the opposite sign as its value. That is, a CFD position with a long quantity of say 10 with a price of £1.00 has a value of +£10.00 but it must be negated and given a consideration of -£10.00. The EquityClear member reports showing margin positions provide the data in this way.

4.1.2 Cash only positions

Cash only positions arise from cash claims such as interest or dividend payments. They will have a net quantity of zero and net consideration of the cash amount.

LCH will provide "equity" and "price" data relating to cash only positions with a dummy ISIN of 'CASH'. Given this, cash only positions can be treated exactly the same as equity positions throughout the LCH ERA calculations.

4.2 Price

For CFD related calculations, Members should use the CFD price equivalent file named 'OTCCFDPrice.csv'. The file format and structure are exactly the same as defined below.

The CFD related files are available in the CFD Margin Parameters content in the LCH secure area.

Field	Data Type	Description
ISIN	Varchar(12)	ISIN code of the instrument. Set to CASH for cash only deliveries.
Currency	Char(3)	ISO code of the currency of denomination of the ISIN.
Date	Date	Date of the price.
Bid	Numeric(6)	Latest bid price for the current business day. Will be zero for all historic dates. Represented in major denomination unit (e.g. GBP = pounds, EUR = euros.)
Mid	Numeric(6)	Latest mid price for the date, hence the closing price for all historic dates. Represented in major denomination unit (e.g. GBP = pounds, EUR = euros.)
Ask	Numeric(6)	Latest ask price for the current business day. Will be zero for all historic dates. Represented in major denomination unit (e.g. GBP = pounds, EUR = euros.)
Price change	Numeric(6)	For ISINs margined in a portfolio method bucket, this will be the fractional price change using its bucket parameters.
Days offset	Integer	This gives the number of valid price business days back relative to the current business day (e.g. the current business day = 0, for the previous price date = 1, and so on.)

4.2.1 Currency of Risk

A price file per possible Currency of Risk will be provided. Members should use the appropriate price file aligned to the product and their Currency of Risk.

- For cash equities GBP select 'Price.csv'
- For CFD GBP select 'OTCCFDPrice.csv'
- For currency XXX select 'PriceXXX.csv' or the CFD equivalent 'OTCCFDPriceXXX.csv' e.g. for EUR select 'PriceEUR.csv' or 'OTCCFDPriceEUR.csv'

4.3 Exchange rate

The dataset must include entries between a currency and itself with an exchange rate of 1.

Field	Data Type	Description
From currency	Char(3)	ISO code of the currency to which the exchange rate is to be applied.
To currency	Char(3)	ISO code of the currency of the result of the exchange rate application.

Date	Date	Date of the price.
Mult exchange rate	Numeric(6)	The value which the 'From' amount should be multiplied by to get the 'To' amount.

4.4 Equity

For CFD related calculations, Members should use the CFD equity equivalent file named 'OTCCFDEquity.csv'. The file format and structure are exactly the same as defined below.

The CFD related files are available in the CFD Margin Parameters content in the LCH secure area.

Field	Data Type	Description
ISIN	Varchar(12)	This is the ISIN code of the instrument. Set to CASH for cash only deliveries.
Name	Varchar(255)	Name of the instrument.
Currency	Char(3)	This is the ISO code of the currency of denomination of the ISIN.
Assume settlement	Boolean	TRUE = settlement assumed. FALSE = settlement not assumed.
VM price	Char(3)	MID = use MID price for credit & debit position. B/A = use BID price for credit (+ve) position and ASK price for debit (-ve) position.
Bucket code	Varchar(20)	The initial margin bucket appropriate to this instrument.

4.5 Bucket

Field	Data Type	Description
Bucket code	Varchar(20)	The bucket code used to reference the following parameters.
Price history days	Integer	For portfolio: the number of historic days prices to be used (including the current day).
Time horizon	Integer	For portfolio: the number of contiguous prices across which price changes are calculated.
Currency	Char(3)	For portfolio: the currency in which all values are calculated.
Discarded portfolio losses	Integer	For portfolio: the number of largest portfolio value changes to be discarded for the purpose of margin calculation.
Averaged portfolio losses	Integer	For portfolio: the number of subsequent largest portfolio value changes to be averaged to calculate the base margin.
Risk coefficient	Numeric(2)	For portfolio: the factor by which the base margin is multiplied.
Bucket type	Char(1)	P = portfolio, F = flat rate.
Risk rate	Numeric(3)	For flat rate: the fraction of the current position value to be collected as margin.

4.5.1 Currency of Risk

Members should populate the 'Currency' field with the appropriate currency aligned to their Currency of Risk

4.6 Global

This dataset has only one record

Field	Data Type	Description
Current business date	Date	Business date for the current margin run.
Margin run type	Char(3)	EOD = end-of-day, ITD = intra-day.
Next LCH business date	Date	The next date on which margins will be calculated.
CVM date	Date	A date used in the calculation of variation margin.
Counterparty multiplier	Numeric(2)	A factor used in calculating the final margin requirement.
LCH base currency	Char(3)	This is the currency in which the final initial and variation margins will be calculated, reported and posted as liabilities/assets to the members account within LCH for cover purposes.
Liquidity Margin Rate	Numeric(2)	<i>No longer used.</i>

4.6.1 Currency of Risk

Members should populate the 'LCH base Currency' field with the appropriate currency aligned to their Currency of Risk

4.7 Daily Volume

Field	Data Type	Description
ISIN	Varchar(12)	This is the ISIN code of the instrument.
Currency	Char(3)	This is the ISO code of the currency of denomination of the ISIN.
Volume	Integer	Average daily traded volume for the security.

4.8 LCRM

This dataset has only one record

Field	Data Type	Description
HP factor	Numeric(6)	The holding period factor used in the LCRM calculation
HP standard	Integer	Standard holding period used in the LCRM calculation
HP max	Integer	The holding period limit used in the LCRM calculation

4.9 LCRM Bucket

Field	Data Type	Description
-------	-----------	-------------

Bucket code	Varchar(20)	The bucket code used to reference the following parameters.
Bucket rate	Numeric(3)	The risk rate to be used in the LCRM calculation for positions with a portfolio bucket type.

4.10 Account

The Currency of Risk is setup at the individual Margin Account level for each member (Please refer to Section 4.1 Account and Positions for Account Structure. The Currency is set by LCH based on the Clearing Portfolio in the associated position accounts.

This will not be a part of the ERA files and will be communicated by LCH Collateral Ops to the members.

5. LCH ERA Calculation Detail

This section describes in detail the calculation steps required to perform the margin calculations of the LCH ERA algorithm from a set of input data as defined in the previous section.

5.1 Accounts & Positions

An account holds a set of positions. EquityClear has two account levels, position accounts and margin accounts. A margin account holds the net of the position accounts cleared through it.

EMIR introduced the requirement for CCPs and their clearing members to offer the clients of the clearing member the option to have their positions risk managed on an individually segregated basis at the CCP.

The diagram below shows a general clearing member (GCM) arrangement for their client business with a traditional net omnibus margin account (OSA) with margin account ID XXX/C and an individually segregated client account (ISA) with margin account ID XXX/C/SFID3. The positions in XXX/C are the net of the positions in position accounts SFID1 and SFID2, whilst the positions in XXX/C/SFID3 are simply the same as the positions in SFID3.

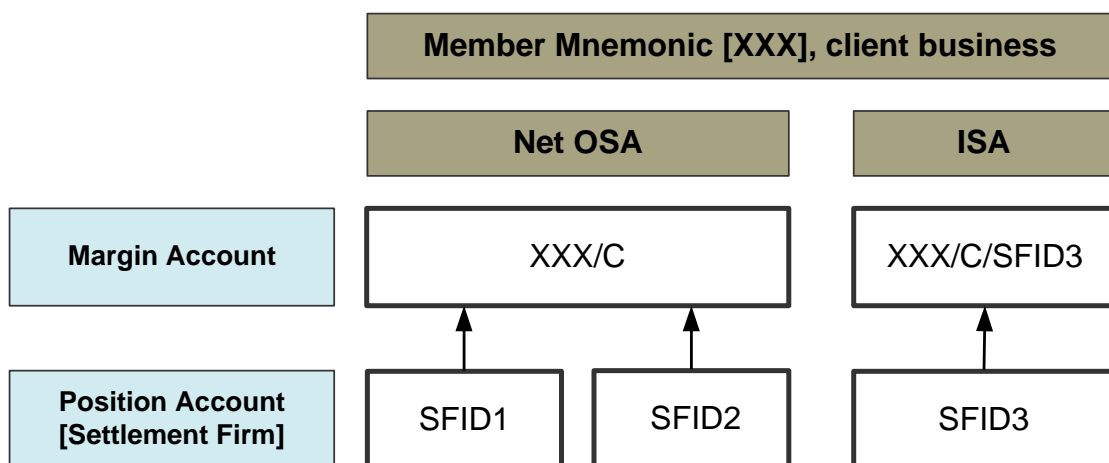

LCH calculates margin to collect from clearing members at the margin account level. In this case this would be separately for both XXX/C and XXX/C/SFID3. The GCM would calculate and collect margin from its clients at the position account level, i.e. for SFID1, SFID2 and SFID3 separately.

To calculate the margin requirement for account XXX/C the input position set would be the positions in XXX/C. The ERA algorithm would be applied on this position set to calculate the variation margin, initial margin and wrong way risk margin. In calculating the LCRM for account XXX/C the calculation takes into account the positions in the margin accounts for all the GCM's client business, that is the OSA and the ISA. The same applies in calculating LCRM on an ISA. This is covered fully in the LCRM calculation section.

5.2 Variation Margin

5.2.1 Eligible positions

For intra-day variation margin calculations, the eligible positions are all the original positions in the source 'position' file with no filtering or netting applied.

For end-of-day variation margin calculations, LCH ERA assumes settlement of positions that can or probably will settle early on the next LCH business day and removes them from the margin calculation.

Whether settlement of an equity position should be assumed is determined by the 'assume settlement' flag for each equity (see 4.4). The flag would be set to not assume settlement (value = 'FALSE') if the next LCH business day was a currency holiday for the settlement currency of the equity, or if there were market reasons why settlement of the equity was not likely. The flag is set to assume settlement otherwise (value = 'TRUE').

Therefore, the positions assumed to settle are those for which

'equity: ISIN' = 'position: ISIN'
 and 'equity: Currency' = 'position: Currency'
 and 'equity: Assume settlement' = 'TRUE'
 and 'position: ISD' <= 'global: Next LCH business day'.

The eligible end-of-day positions are therefore the starting position set, less those positions assumed to settle.

This data set will be referenced as 'vm position: <fieldname>'.

5.2.2 Calculation of Equity Variation Margin (EVM)

The 'price' input data file is used for both variation and initial margin calculation. For the variation margin calculation, only prices dated for the current business date are relevant. That is, where

'price: Date' = 'global: Current business date'.

The price used will be for the ISIN and currency specified in the position record. That is, where

'price: ISIN' = 'vm position: ISIN'
 and 'price: Currency' = 'vm position: Currency'.

Further, the price used to determine the current value of a position is determined from 'equity: VM price' and the direction of the position (buy or sell). LCH's Risk Department will set the 'equity: VM price' parameter to specify whether mid prices or bid/ask prices are to be used to calculate variation margin for each instrument.

Where the 'equity: VM price' = MID, the 'price: Price type' = 'MID' is used.

Where the 'equity: VM price' = B/A,

the 'price: Price type' = 'BID' is used for a long/buy position ('position: Net quantity' is a credit (+ve)),

the 'price: Price type' = 'ASK' is used for a short/sell position ('position: Net quantity' is a debit (-ve)).

For each eligible position record, using the appropriate price, the 'equity variation margin' is calculated as:

('vm position: Net quantity' * 'price: Price') + ('vm position: Net consideration')

Please note, this is the difference between the current value and the settlement value even though an addition appears to be being carried out. Please see the signing conventions of 'position: Net quantity' and 'position: Net consideration' defined in section 0.

Equity variation margin could be similarly calculated on a trade-by-trade basis using this method. In order for the sum of the equity variation margin for each trade to match the net position value, the use of bid or ask prices must be based on the sign of the net quantity of the position and not the sign of the quantity of each trade.

5.2.3 Calculation of Total Variation Margin

'Restricted credit variation margin' is defined as the net credit variation margin arising from trades that may settle before the margin call PPS (Protected Payments System) confirmation cut-off time (9:00 am) following the next end-of-day margin run. It is restricted from use as credit variation margin because the asset value is not guaranteed to LCH as it ceases to be a realisable asset on settlement.

Whilst the concept of 'restricted credit variation margin' seems complex, its calculation within LCH ERA is simply executed, as described below, through the use of the 'global: CVM date' parameter supplied by LCH.

The 'total variation margin' is the sum of the 'equity variation margins' less any 'restricted credit variation margin'.

5.2.3.1 Separating EVMs for Credit Offset Restriction

The calculation of total variation margin is performed by first summing the 'equity variation margin' for two distinct groups; the group of 'restricted credit variation margin' positions, being those that may settle before PPS confirmation following the next end-of-day margin call, and the group of 'unrestricted credit variation margin' positions, being the rest.

LCH will define the date 'global: CVM date' to distinguish the two groups as follows.

The restricted credit variation margin positions are those where

$$\text{'vm position: ISD'} \leq \text{'global: CVM date'}$$

and the unrestricted credit variation margin positions are those where

$$\text{'vm position: ISD'} > \text{'global: CVM date'}$$

5.2.3.2 Aggregation by Currency

The sum of the equity variation margins for each group is then calculated within currency as the 'currency total'.

5.2.3.3 Aggregation in LCH Base Currency

Any 'currency total' not in the 'global: LCH base currency' is then converted to this currency, using the current exchange rate, as

$$\text{'currency total'} * \text{'exchange rate: Mult exchange rate'}$$

where

$$\text{'exchange rate: From currency'} = \text{'currency total'} \text{ currency}$$

$$\text{and 'exchange rate: To currency'} = \text{'global: LCH base currency'}$$

$$\text{and 'exchange rate: Date'} = \text{'global: Current business date'}$$

The total for each group is then calculated in the LCH base currency.

5.2.3.4 Final Calculation of Total Variation Margin

If the total for the 'restricted credit variation margin group' is negative (i.e. a debit) then no credit variation margin exists for this group, no restriction applies and hence

$$\text{total variation margin} = \text{the sum of the two group totals.}$$

If the total for the 'restricted credit variation margin group' is positive (i.e. a credit) then a restricted credit variation margin exists and

$$\text{total variation margin} = \text{the 'unrestricted credit variation margin' group total.}$$

Please note that this is the same as the total variation margin, less any restricted credit variation margin.

The total variation margin is rounded to a settleable amount in the LCH base currency. For example, a total variation margin of £456.35507 would be rounded to £456.36.

5.3 Initial Margin

5.3.1 Eligible positions

The 'vm position' dataset is converted to the 'base im positions' dataset by removing the 'ISD' and 'net consideration' fields and re-netting the 'net quantity'.

The eligible positions used for initial margin calculation are the positions in the 'base im positions' dataset less the positions to which wrong way risk is applied; i.e. excluding the positions in the 'ww position' dataset. This data set will be referenced as 'im position: <fieldname>'.

5.3.2 Portfolio Method

The portfolio method is used for all positions where the instrument is defined as being margined by the portfolio method in the 'bucket' data. That is, where

- 'im position: ISIN' = 'equity: ISIN'
- and 'im position: Currency' = 'equity: Currency'
- and 'equity: Bucket code' = 'bucket: Bucket code'
- and 'bucket: Bucket type' = 'P'.

5.3.2.1 Calculation by Bucket

5.3.2.1.1 Calculation of the Price Change Parameters

Portfolio initial margins are calculated using historic price changes. LCH calculates and provides the required price change parameters in the 'price' file as 'price: Price change' in GBP, **therefore they do not need to be recalculated.**

Should a Member have a Currency of Risk of EUR or USD, the relevant price file should be used which will capture the required price change parameters.

The price change parameters are calculated by LCH as described below.

The method can be used where prices or exchange rates that are different from those supplied by LCH are used. The days offset parameters are provided as 'price: Days offset' to assist in the calculation, particularly if SQL is used.

The price changes are required for each instrument for a range of historic dates. The length of the price history, in days, is specified as parameter 'bucket: Price history days'. The number of days over which each price change is to be measured is specified as parameter 'bucket: Time horizon'. Therefore, the number of price changes calculated per equity in the bucket is

$$\text{'bucket: Price history days'} - \text{'bucket: Time horizon'}$$

To allow instruments settled in different currencies to be margined together all price changes are calculated in the bucket base currency specified as parameter 'bucket: Currency'.

Only mid prices are used to calculate the price changes.

Prices not in the bucket base currency are converted to that currency, using the exchange rate from the same date as the price, as

$$\text{'price: Mid'} * \text{'exchange rate: Mult exchange rate'}$$

where

- 'price: ISIN' = 'equity: ISIN'
- and 'price: Currency' = 'equity: Currency'
- and 'equity: Bucket code' = 'bucket: Bucket code'
- and 'exchange rate: From currency' = 'price: Currency'

and 'exchange rate: To currency' = 'bucket: Currency'
 and 'exchange rate: Date' = 'price: Date'.

For each instrument in the bucket, the price change for each day is calculated as

$$(P_{D-T} - P_D) / P_D$$

where

P_x is the mid price (in bucket base currency) appropriate to 'x' = 'Days offset'

D is the 'price: Days offset' of the earlier date

T is the 'bucket: Time horizon' of the bucket.

For example, for an instrument in a bucket with a 'Time horizon' of 2 days and a 'Currency' of GBP, where today is 22/5/2001 and the price of the equity on 'Days offset = 5' (15/5/2001) is £10 and its price on 'Days offset = 3' (17/5/2001) is £12 then the price change for 'Days offset = 5' is $(12-10)/10 = 0.2$.

LCH rounds the price changes to six decimal places.

5.3.2.1.2 Calculation of the Position Current Value

Portfolio initial margins are calculated using the current value of each position in the bucket base currency. The current value for each position is calculated as the product of the net quantity, the current mid price and the current exchange rate from the equity currency to the bucket base currency. That is,

$$\text{'im position: Net quantity'} * \text{'price: Mid'} * \text{'exchange rate: Mult exchange rate'}$$

where

'equity: ISIN' = 'im position: ISIN'
 and 'equity: Currency' = 'im position: Currency'
 and 'equity: ISIN' = 'price: ISIN'
 and 'equity: Currency' = 'price: Currency'
 and 'equity: Bucket code' = 'bucket: Bucket code'
 and 'exchange rate: To currency' = 'bucket: Currency'
 and 'exchange rate: From currency' = 'price: Currency'
 and 'exchange rate: Date' = 'price: Date'
 and 'global: Current business date' = 'price: Date'.

This value will be henceforth referenced as 'im position: Current value'.

5.3.2.1.3 Calculation of the Daily Portfolio Value Changes

For each day in the price change history calculate the daily portfolio value change. This is the absolute value of the sum of the product of the price changes and position current values for each instrument in the bucket. That is,

$$\text{Daily portfolio value change} = \text{abs} \left(\sum_{\text{for 'price: Days offset'}} \left(\sum_{\text{for all ISINs in the bucket}} \left(\text{'im position: Current value'} * \text{'price: Price change'} \right) \right) \right)$$

where

'im position: ISIN' = 'price: ISIN'
 and 'im position: Currency' = 'price: Currency'.

The "abs()" operation, applied after the sum of the products, ensures that the price change results are all absolute magnitudes (i.e. all positive).

5.3.2.1.4 Calculation of the Base Initial Margin

The daily portfolio value changes are then in effect ranked in descending order, the largest 'N' are discarded and the next 'M' are averaged where

'N' = 'bucket: Discarded portfolio losses' and

'M' = 'bucket: Averaged portfolio losses'.

The result is then made negative to give the 'base initial margin'. This is because all initial margins are debits against the account being margined.

For example, if five daily value changes of 100, 300, 200, 500, 400 were calculated and N=1 and M=2, then calculation of the base initial margin would discard the largest change, 500, and average the next two largest changes, $(400+300)/2=350$, and then make the result negative as -350.

5.3.2.1.5 Application of the Risk Coefficient

The 'base initial margin' is then multiplied by the 'bucket: Risk coefficient' to give the 'portfolio initial margin'.

5.3.2.2 Aggregation by Currency

All 'portfolio initial margins' with the same currency are then added together to give a single 'portfolio initial margin' per currency or 'currency total'.

5.3.2.3 Aggregation in LCH Base Currency

Any 'currency total' not in the 'global: LCH base currency' is then converted to this currency as

'currency total' * 'exchange rate: Mult exchange rate'

where

'exchange rate: From currency' = 'currency total' currency

and 'exchange rate: To currency' = 'global: LCH base currency'

and 'exchange rate: Date' = 'global: Current business date'.

The total is then calculated as the sum of these results in the LCH base currency.

5.3.2.4 Application of Multipliers

The total margin in LCH base currency is multiplied by the 'global: Counterparty multiplier'¹ and rounded to a settleable amount to give the total portfolio initial margin.

For example, if the total margin in LCH base currency (GBP) is -123.45668 and the counterparty multiplier is 1.5, the result is -185.18502, which rounded to the nearest penny is £-185.19.

¹ LCH will notify a participant if the value applicable to them differs from that published.

5.3.3 Flat Rate Method

The flat rate method is used for all positions where the instrument is defined as being margined by the flat rate method in the 'bucket' data. That is, where

- 'im position: ISIN' = 'equity: ISIN'
- and 'im position: Currency' = 'equity: Currency'
- and 'equity: Bucket code' = 'bucket: Bucket code'
- and 'bucket: Bucket type' = 'F'.

5.3.3.1 Calculation by Position

The initial margin for each appropriate position is calculated as an LCH Risk defined fraction, the 'bucket: Risk rate', of the current value of the position in the currency of the equity. That is,

$$- \text{abs}(\text{'im position: Net quantity'} * \text{'price: Mid'} * \text{'bucket: Risk rate'})$$

where

- 'equity: ISIN' = 'im position: ISIN'
- and 'equity: Currency' = 'im position: Currency'
- and 'equity: ISIN' = 'price: ISIN'
- and 'equity: Currency' = 'price: Currency'
- and 'equity: Bucket code' = 'bucket: Bucket code'
- and 'global: Current business date' = 'price: Date'.

The "- abs()" operation ensures the result is always a member debit (i.e. negative).

5.3.3.2 Aggregation by Currency

The sum of the flat rate margins is then calculated within currency as the 'currency total'.

5.3.3.3 Aggregation in LCH Base Currency

Any 'currency total' not in the 'global: LCH base currency' is then converted to this currency as

$$\text{'currency total'} * \text{'exchange rate: Mult exchange rate'}$$

where

- 'exchange rate: From currency' = 'currency total' currency
- and 'exchange rate: To currency' = 'global: LCH base currency'
- and 'exchange rate: Date' = 'global: Current business date'.

The total is then calculated as the sum of these results in the LCH base currency.

Please note: The 'global:LCH Base Currency' field should be updated to reflect the member's currency of risk

5.3.3.4 Application of Counterparty Multiplier

The total margin in LCH base currency is multiplied by the 'global: Counterparty multiplier' and rounded to a settleable amount to give the total flat rate initial margin.

Please note: The 'global:LCH Base Currency' field should be updated to reflect the member's currency of risk

5.3.4 Total Initial Margin

The total initial margin is the sum of the total portfolio initial margin and the total flat rate initial margin.

5.4 Wrong Way Risk Margin

5.4.1 Eligible positions

The 'vm position' dataset is converted to the 'base im positions' dataset by removing the 'ISD' and 'net consideration' fields and re-netting the 'net quantity'.

The eligible positions for wrong way risk calculation are the 'base im positions', where a Clearing Member holds a position in its own stock (including CFDs) where the net position quantity is long [+ve].

This data set will be referenced as 'ww position: <fieldname>'.

5.4.2 Calculation by Position

The wrong way risk margin for each eligible position is calculated as 100% of the current value of the position in the currency of the equity. That is,

$$- \text{abs}(\text{'ww position: Net quantity'} * \text{'price: Mid'})$$

where

$$\begin{aligned} \text{'ww position: ISIN'} &= \text{'price: ISIN'} \\ \text{and 'ww position: Currency'} &= \text{'price: Currency'} \\ \text{and 'global: Current business date'} &= \text{'price: Date'} \\ \text{and 'ww position: Net quantity'} &> 0 \end{aligned}$$

5.4.3 Aggregation by Currency

The sum of the margins is then calculated within currency as the 'currency total'.

5.4.4 Aggregation in LCH Base Currency

Any 'currency total' not in the 'global: LCH base currency' is then converted to this currency as

$$\text{'currency total'} * \text{'exchange rate: Mult exchange rate'}$$

where

$$\begin{aligned} \text{'exchange rate: From currency'} &= \text{'currency total'} \text{ currency} \\ \text{and 'exchange rate: To currency'} &= \text{'global: LCH base currency'} \\ \text{and 'exchange rate: Date'} &= \text{'global: Current business date'}. \end{aligned}$$

The total wrong way risk margin is the sum of the results in the LCH base currency rounded to a settleable amount.

Please note: The 'global:LCH Base Currency' field should be updated to reflect the member's currency of risk

5.5 Liquidity and Concentration Risk Margin

5.5.1 Eligible positions

The eligible positions for LCRM calculation are the 'im positions' which are not margined by the flat rate method at 100% or more. That is, the eligible positions are where

$$\begin{aligned} \text{'im position: ISIN'} &= \text{'equity: ISIN'} \\ \text{and 'im position: Currency'} &= \text{'equity: Currency'} \\ \text{and 'equity: Bucket code'} &= \text{'bucket: Bucket code'} \\ \text{and ('bucket: bucket type')} &= \text{'P'} \end{aligned}$$

or ('bucket: bucket type' = 'F' and 'bucket: Risk rate' < 1))

This eligible position dataset will be referenced as 'lcm position: <fieldname>'.

5.5.2 Qualifying positions

Where the calculation is for a client margin account then the equivalent eligible positions from all client margin accounts for that member are to be aggregated, that is long and short positions netted separately into a new dataset 'lcrm position'. If there is only one client margin account, almost certainly an OSA, then this is the same as the eligible dataset 'lcm position'.

The LCRM calculation uses a derived new holding period value 'HP new' which is an integer.

'lcrm position: HP new' = abs('lcrm position: net quantity') / ('daily volume: volume' * 'LCRM: HP factor')

where

'lcrm position: ISIN' = 'daily volume: ISIN'

and 'lcrm position: Currency' = 'daily volume: Currency'

If 'HP new' is not an integer it is rounded up to the next integer. i.e. 2.1 rounds up to 3.

'HP new' is limited to a maximum holding period 'LCRM: HP max', so if 'HP new' > 'LCRM: HP max' then 'HP new' is set to 'LCRM: HP max'.

Where 'HP new' is not greater than the standard holding period 'LCRM: HP standard' no LCRM arises. In this case, setting 'HP new' to 'LCRM: HP standard' achieves this result as the 'HP coefficient' becomes zero later in the calculation.

Therefore 'LCRM: HP standard' ≤ 'lcrm position: HP new' ≤ 'LCRM: HP max'

5.5.3 Calculation by Position

LCRM is calculated for each eligible position which has a corresponding position in the 'lcrm position' dataset and where the direction of the positions are the same. That is where:

'lcm position: ISIN' = 'lcrm position: ISIN'

and 'lcm position: Currency' = 'lcrm position: Currency'

and ('lcm position: Net quantity' / 'lcrm position: Net quantity') =
abs('lcm position: Net quantity' / 'lcrm position: Net quantity')

The LCRM for each such eligible position is calculated from the current position value and a derived LCRM coefficient.

'current position value' = 'lcm position: net quantity' * 'price: Mid'

where

'lcm position: ISIN' = 'price: ISIN'

and 'lcm position: Currency' = 'price: Currency'

and 'global: Current business date' = 'price: Date'.

The LCRM coefficient is calculated from two components, an 'HP coefficient' and an 'LCRM bucket rate'.

HP coefficient = $(\sqrt{('lcrm\ position: HP_{new}' / 'LCRM: HP_{std}') - 1})$

where

'Im position: ISIN' = 'lcrm position: ISIN'
 and 'Im position: Currency' = 'lcrm position: Currency'

The 'LCRM bucket rate' is sourced differently for positions whose initial margin calculation is by the flat rate method and those whose initial margin calculation is by the portfolio method.

For positions whose initial margin calculation is by the flat rate method, the 'LCRM bucket rate' is the same as the initial margin risk rate. That is,

'LCRM bucket rate' = 'bucket: Risk rate'

where

'equity: ISIN' = 'Im position: ISIN'
 and 'equity: Currency' = 'Im position: Currency'
 and 'equity: Bucket code' = 'bucket: Bucket code'
 and 'bucket: Bucket type' = 'F'.

For positions whose initial margin calculation is by the portfolio method, the 'LCRM bucket rate' is defined in a new file 'LCRM bucket'. That is,

'LCRM bucket rate' = 'LCRM bucket: Risk rate'

'equity: ISIN' = 'lcrm position: ISIN'
 and 'equity: Currency' = 'lcrm position: Currency'
 and 'equity: Bucket code' = 'bucket: Bucket code'
 and 'bucket: Bucket code' = 'LCRM bucket: Bucket code'
 and 'bucket: bucket type' = 'P'

The LCRM coefficient = 'HP coefficient' * 'LCRM bucket rate', limited to a maximum value of 1.

The position LCRM = 'current position value' * 'LCRM coefficient'

5.5.4 Aggregation by Currency

The sum of the LCRMs is then calculated within currency as the 'currency total'.

5.5.5 Aggregation in LCH Base Currency

Any 'currency total' not in the 'global: LCH base currency' is then converted to this currency as

'currency total' * 'exchange rate: Mult exchange rate'

where

'exchange rate: From currency' = 'currency total' currency
 and 'exchange rate: To currency' = 'global: LCH base currency'

and 'exchange rate: Date' = 'global: Current business date'.

The total LCRM is the sum of the results in the LCH base currency rounded to a settleable amount.

5.6 Rounding Rules

LCH rounds the historic price changes to six decimal places (6dp) for inclusion in the 'price' file (section 5.3.2.1.1). If the price change figures are recalculated they should similarly be rounded to ensure reconciliation.

Otherwise, rounding of values only takes place as the final action in generating the total variation margin (section 5.2.3.4), the total portfolio initial margin (section 5.3.2.4) the total flat rate initial margin (section 5.3.3.4), the total wrong way risk margin (section 4.4.4) and the total LCRM (section 4.5.5).

Rounding takes place to the nearest settleable unit; e.g. for sterling (GBP) this is the nearest penny.

When rounding, 'halves' round up in absolute terms. That is

0.005 rounds to 0.01 (e.g. £1.555 rounds to £1.56) and

-0.005 rounds to -0.01 (e.g. £-1.555 rounds to £-1.56).

6. Worked Examples

Two worked examples of initial margin and variation margin calculations are shown. The first is for the end-of-day margin run of 22 May 2001 and the second is for the subsequent formal intra-day margin run on 23 May 2001. The full input data set is shown for each margin run in table form here and as sample files in the following section. Please note that some of the intermediate results shown have been rounded for presentation purposes only, with calculation accuracy being used as defined by the algorithm.

6.1 IM & VM for end-of-day 22/5/2001

Global

Current business date	Margin run type	Next LCH business date	CVM date	Counterparty multiplier	LCH base currency	Liquidity margin rate
22/5/2001	EOD	23/5/2001	24/5/2001	1.5	GBP	12.34

Bucket

Bucket code	Price history days	Time horizon	Currency	Discarded portfolio losses	Averaged portfolio losses	Risk coefficient	Bucket type	Risk rate
LIQUID1	6	2	GBP	1	2	1.25	P	
LIQUID2	6	2	EUR	2	1	1.3	P	
FLAT5							F	0.05
FLAT10							F	0.10
FLAT0							F	0.00

Equity

ISIN	Name	Currency	Assume settlement	VM price	Bucket code
XE1111111111	IRL BANK	EUR	TRUE	MID	LIQUID1
XE2222222222	IRL TELECOM	EUR	FALSE	B/A	LIQUID2
XE3333333333	COMPANIE	EUR	TRUE	MID	FLAT5
XG0000000001	ABC PLC	GBP	FALSE	MID	LIQUID1
XG0000000002	DEF PLC	GBP	TRUE	B/A	FLAT5
XG0000000003	GHI PLC	GBP	TRUE	MID	FLAT10
CASH	EUR cash only	EUR	TRUE	MID	FLAT0
CASH	GBP cash only	GBP	TRUE	MID	FLAT0

Exchange rate

From currency	To currency	Date	Mult exchange rate
EUR	GBP	15/5/2001	0.728916
EUR	GBP	16/5/2001	0.719424
EUR	GBP	17/5/2001	0.714235
EUR	GBP	18/5/2001	0.714286
EUR	GBP	21/5/2001	0.716846
EUR	GBP	22/5/2001	0.735294
GBP	EUR	15/5/2001	1.371900
GBP	EUR	16/5/2001	1.390000
GBP	EUR	17/5/2001	1.400100
GBP	EUR	18/5/2001	1.400000
GBP	EUR	21/5/2001	1.395000
GBP	EUR	22/5/2001	1.360000
EUR	EUR	15/5/2001	1.000000
EUR	EUR	16/5/2001	1.000000
EUR	EUR	17/5/2001	1.000000
EUR	EUR	18/5/2001	1.000000
EUR	EUR	21/5/2001	1.000000
EUR	EUR	22/5/2001	1.000000
GBP	GBP	15/5/2001	1.000000
GBP	GBP	16/5/2001	1.000000
GBP	GBP	17/5/2001	1.000000
GBP	GBP	18/5/2001	1.000000
GBP	GBP	21/5/2001	1.000000
GBP	GBP	22/5/2001	1.000000

Price

ISIN	Currency	Date	Bid	Mid	Ask	Price change	Days offset
XE1111111111	EUR	15/5/2001		12.5		-0.043657	5
XE1111111111	EUR	16/5/2001		12.495		-0.021842	4
XE1111111111	EUR	17/5/2001		12.2		0.013528	3
XE1111111111	EUR	18/5/2001		12.31		0.063697	2
XE1111111111	EUR	21/5/2001		12.32			1
XE1111111111	EUR	22/5/2001		12.72			0
XE2222222222	EUR	15/5/2001	0.21	0.23	0.25	0.021739	5
XE2222222222	EUR	16/5/2001	0.22	0.2275	0.235	0.252747	4
XE2222222222	EUR	17/5/2001	0.225	0.235	0.245	0.180851	3
XE2222222222	EUR	18/5/2001	0.27	0.285	0.3	-0.157895	2
XE2222222222	EUR	21/5/2001	0.26	0.2775	0.295		1
XE2222222222	EUR	22/5/2001	0.235	0.24	0.245		0
XE3333333333	EUR	22/5/2001		123.45			0
XG0000000001	GBP	15/5/2001		4.6		-0.086957	5
XG0000000001	GBP	16/5/2001		4.57		-0.083151	4
XG0000000001	GBP	17/5/2001		4.2		0.042857	3
XG0000000001	GBP	18/5/2001		4.19		0.050119	2
XG0000000001	GBP	21/5/2001		4.38			1
XG0000000001	GBP	22/5/2001		4.4			0
XG0000000002	GBP	22/5/2001	12.96	12.99	13.02		0
XG0000000003	GBP	22/5/2001		0.5			0
CASH	EUR	22/5/2001		0			0
CASH	GBP	22/5/2001		0			0

Position (NB Field 'Account' is not shown as this example is for a single account)

ISIN	ISD	Currency	Net quantity	Net consideration
XG0000000002	18/5/2001	GBP	-500	+6000.00
XE1111111111	23/5/2001	EUR	+123	-1512.90
XE2222222222	22/5/2001	EUR	-200	+46.00
XE1111111111	24/5/2001	EUR	+1000	-12300.00
XE2222222222	24/5/2001	EUR	+1000	-280.00
XE3333333333	24/5/2001	EUR	-300	+36900.40
XG0000000001	23/5/2001	GBP	+100	-419.25
XG0000000001	24/5/2001	GBP	-700	+3067.25
XG0000000002	24/5/2001	GBP	-240	+3024.30
XG0000000001	25/5/2001	GBP	+200	-881.40
XG0000000002	25/5/2001	GBP	+400	-5400.00
XG0000000003	25/5/2001	GBP	-600	+299.90
CASH	29/5/2001	GBP	0	-199.99
XE1111111111	25/5/2001	EUR	+1000	-12719.30
XE2222222222	25/5/2001	EUR	+1000	-233.60
CASH	4/6/2001	EUR	0	+12.34

im position (derived for initial margin see section 4.3.1)

ISIN	Currency	Net quantity
XE1111111111	EUR	+2000
XE2222222222	EUR	+1800
XE3333333333	EUR	-300
XG0000000001	GBP	-400
XG0000000002	GBP	+160
XG0000000003	GBP	-600
CASH	GBP	0
CASH	EUR	0

Variation Margin Calculation

Date boundary functions	ISIN	ISD	Assume settlement	Currency	Net quantity (Q)	Net consideration (C)	VM price	Price 4.2.2 (P)	Equity VM 4.2.2 (Q*P + C)	By position currency 4.2.3.2	In LCH base currency 4.2.3.3	Total VM 4.2.3.4
Assumed settled 4.2.1	XG0000000002	18/5/2001	TRUE	GBP	-500	+6000.00						
	XE1111111111	23/5/2001	TRUE	EUR	+123	-1512.90						
	XE2222222222	22/5/2001	FALSE	EUR	-200	+46.00	B/A	0.245	-3.00	237.40	82.0587956	-406.87
	XE1111111111	24/5/2001	TRUE	EUR	+1000	-12300.00	MID	12.72	420.00			
	XE2222222222	24/5/2001	FALSE	EUR	+1000	-280.00	B/A	0.235	-45.00			
	XE3333333333	24/5/2001	TRUE	EUR	-300	+36900.40	MID	123.45	-134.60			
	XG0000000001	23/5/2001	FALSE	GBP	+100	-419.25	MID	4.4	20.75	-92.50		
	XG0000000001	24/5/2001	FALSE	GBP	-700	+3067.25	MID	4.4	-12.75			
Credit VM restriction	XG0000000002	24/5/2001	TRUE	GBP	-240	+3024.30	B/A	13.02	-100.50			
4.2.3.1	XG0000000001	25/5/2001	TRUE	GBP	+200	-881.40	MID	4.4	-1.40	-417.49	-406.87235464	
	XG0000000002	25/5/2001	TRUE	GBP	+400	-5400.00	B/A	12.96	-216.00			
	XG0000000003	25/5/2001	TRUE	GBP	-600	+299.90	MID	0.5	-0.10			
	CASH	29/5/2001	TRUE	GBP	0	-199.99	MID	0	-199.99			
	XE1111111111	25/5/2001	TRUE	EUR	+1000	-12719.30	MID	12.72	0.70	14.44		
	XE2222222222	25/5/2001	FALSE	EUR	+1000	-233.60	B/A	0.235	1.40			
	CASH	4/6/2001	TRUE	EUR	0	+12.34	MID	0	12.34			

Price changes calculation for equity of ISIN 'XE1111111111' (4.3.2.1.1)

Days offset [D]	5	4	3	2	1	0
Date	15/5/2001	16/5/2001	17/5/2001	18/5/2001	21/5/2001	22/5/2001
Mid price (EUR)	12.5	12.495	12.2	12.31	12.32	12.72
Mult exchange rate (EUR to GBP)	0.728916	0.719424	0.714235	0.714286	0.716846	0.735294
Mid price (GBP) [P]	9.11145	8.98920288	8.713667	8.79286066	8.83154272	9.35293968
Δ Price (over 2 days) [(P _{D-2} - P _D)/P _D] (to 6 d.p.)	-0.043657	-0.021842	0.013528	0.063697		

Base initial margin calculation for bucket 'LIQUID1'

Days offset	5		4		3		2		0
ISIN	Δ Price [Δ P]	Δ Value [Δ P*V] 4.3.2.1.3	Δ Price [Δ P]	Δ Value [Δ P*V] 4.3.2.1.3	Δ Price [Δ P]	Δ Value [Δ P*V] 4.3.2.1.3	Δ Price [Δ P]	Δ Value [Δ P*V] 4.3.2.1.3	Current Value [V] 4.3.2.1.2
XE1111111111	-0.043657	-816.642575	-0.021842	-408.573817	0.013528	253.053136	0.063697	1191.508398	18705.87936 =2000*12.72*0.735294
XG0000000001	-0.086957	153.044320	-0.083151	146.345760	0.042857	-75.428320	0.050119	-88.209440	-1760 =-400*4.4*1
Daily portfolio value change 4.3.2.1.3 Ranking 4.3.2.1.4		663.598255 2		262.228057 3		177.624816 4		1103.298958 1	
Base initial margin 4.3.2.1.4	Drop ranking (1), average rankings (2) and (3), and make the result negative = $-(663.598255 + 262.228057)/2 = -462.913156$								
Portfolio initial margin 4.3.2.1.5	Multiply base initial margin by bucket risk coefficient of 1.25 = $-462.913156 * 1.25 = -578.641445$								

Final initial margin calculations

Portfolio bucket	Currency	Portfolio initial margin 4.3.2.1	By currency 4.3.2.2	In LCH base currency 4.3.2.3	Total portfolio initial margin 4.3.2.4	Total initial margin 4.3.4
LIQUID1	GBP	-578.641445	-578.641445	-643.842782	-965.76	-3209.01
LIQUID2	EUR	-88.673832	-88.673832			
Flat rate ISIN	Currency	Flat rate initial margin 4.3.3.1	By currency 4.3.3.2	In LCH base currency 4.3.3.3	Total flat rate initial margin 4.3.3.4	
XG0000000002	GBP	-103.92	-133.92	-1495.500665	-2243.25	
XG0000000003	GBP	-30.00				
XE3333333333	EUR	-1851.75	-1851.75			

6.2 IM & VM for intra-day 23/5/2001

Global

Current business date	Margin run type	Next LCH business date	CVM date	Counterparty multiplier	LCH base currency	Liquidity margin rate
23/5/2001	ITD	24/5/2001	24/5/2001	1.5	GBP	12.34

Bucket

Bucket code	Price history days	Time horizon	Currency	Discarded portfolio losses	Averaged portfolio losses	Risk coefficient	Bucket type	Risk rate
LIQUID1	6	2	GBP	1	2	1.25	P	
LIQUID2	6	2	EUR	2	1	1.3	P	
FLAT5							F	0.05
FLAT10							F	0.10
FLAT0							F	0.00

Equity

ISIN	Name	Currency	Assume settlement	VM price	Bucket code
XE1111111111	IRL BANK	EUR	TRUE	MID	LIQUID1
XE1111111111	IRL BANK	GBP	TRUE	MID	LIQUID1
XE2222222222	IRL TELECOM	EUR	FALSE	B/A	LIQUID2
XE3333333333	COMPANIE	EUR	TRUE	MID	FLAT5
XG0000000001	ABC PLC	GBP	FALSE	MID	LIQUID1
XG0000000002	DEF PLC	EUR	TRUE	B/A	FLAT5
XG0000000002	DEF PLC	GBP	TRUE	B/A	FLAT5
XG0000000003	GHI PLC	GBP	TRUE	MID	FLAT10
CASH	EUR cash only	EUR	TRUE	MID	FLAT0
CASH	GBP cash only	GBP	TRUE	MID	FLAT0

Exchange rate

From currency	To currency	Date	Mult exchange rate
EUR	GBP	16/5/2001	0.719424
EUR	GBP	17/5/2001	0.714235
EUR	GBP	18/5/2001	0.714286
EUR	GBP	21/5/2001	0.716846
EUR	GBP	22/5/2001	0.735294
EUR	GBP	23/5/2001	0.729820
GBP	EUR	16/5/2001	1.390000
GBP	EUR	17/5/2001	1.400100
GBP	EUR	18/5/2001	1.400000
GBP	EUR	21/5/2001	1.395000
GBP	EUR	22/5/2001	1.360000
GBP	EUR	23/5/2001	1.370200
EUR	EUR	16/5/2001	1.000000
EUR	EUR	17/5/2001	1.000000
EUR	EUR	18/5/2001	1.000000
EUR	EUR	21/5/2001	1.000000
EUR	EUR	22/5/2001	1.000000
EUR	EUR	23/5/2001	1.000000
GBP	GBP	16/5/2001	1.000000
GBP	GBP	17/5/2001	1.000000
GBP	GBP	18/5/2001	1.000000
GBP	GBP	21/5/2001	1.000000
GBP	GBP	22/5/2001	1.000000
GBP	GBP	23/5/2001	1.000000

Price

ISIN	Currency	Date	Bid	Mid	Ask	Price change	Days offset
XE1111111111	EUR	16/5/2001		12.495		-0.021842	5
XE1111111111	EUR	17/5/2001		12.2		0.013528	4
XE1111111111	EUR	18/5/2001		12.31		0.063697	3
XE1111111111	EUR	21/5/2001		12.32		0.066029	2
XE1111111111	EUR	22/5/2001		12.72			1
XE1111111111	EUR	23/5/2001		12.90			0
XE1111111111	GBP	16/5/2001		8.989203		-0.021842	5
XE1111111111	GBP	17/5/2001		8.713667		0.013528	4
XE1111111111	GBP	18/5/2001		8.792861		0.063697	3
XE1111111111	GBP	21/5/2001		8.831543		0.066029	2
XE1111111111	GBP	22/5/2001		9.35294			1
XE1111111111	GBP	23/5/2001		9.414678			0
XE2222222222	EUR	16/5/2001	0.22	0.2275	0.235	0.252747	5
XE2222222222	EUR	17/5/2001	0.225	0.235	0.245	0.180851	4
XE2222222222	EUR	18/5/2001	0.27	0.285	0.3	-0.157895	3
XE2222222222	EUR	21/5/2001	0.26	0.2775	0.295	-0.279279	2
XE2222222222	EUR	22/5/2001	0.235	0.24	0.245		1
XE2222222222	EUR	23/5/2001	0.18	0.2	0.22		0
XE3333333333	EUR	23/5/2001		124.85			0
XG0000000001	GBP	16/5/2001		4.57		-0.083151	5
XG0000000001	GBP	17/5/2001		4.2		0.042857	4
XG0000000001	GBP	18/5/2001		4.19		0.050119	3
XG0000000001	GBP	21/5/2001		4.38		0.050228	2
XG0000000001	GBP	22/5/2001		4.4			1
XG0000000001	GBP	23/5/2001		4.6			0
XG0000000002	EUR	23/5/2001	17.017884	17.072692	17.1275		0
XG0000000002	GBP	23/5/2001	12.42	12.46	12.5		0
XG0000000003	GBP	23/5/2001		0.52			0
CASH	EUR	23/5/2001		0			0
CASH	GBP	23/5/2001		0			0

Position (NB Field 'Account' is not shown as this example is for a single account)

ISIN	ISD	Currency	Net quantity	Net consideration
XE1111111111	23/5/2001	EUR	+123	-1512.90
XE1111111111	24/5/2001	EUR	+1000	-12300.00
XE2222222222	24/5/2001	EUR	+1000	-280.00
XE3333333333	24/5/2001	EUR	-300	+36900.40
XG0000000001	23/5/2001	GBP	+100	-419.25
XG0000000001	24/5/2001	GBP	-700	+3067.25
XG0000000002	24/5/2001	GBP	-240	+3024.30
XG0000000001	25/5/2001	GBP	+200	-881.40
XG0000000002	25/5/2001	GBP	+400	-5400.00
XG0000000003	25/5/2001	GBP	-600	+299.90
CASH	29/5/2001	GBP	0	-199.99
XE1111111111	25/5/2001	EUR	+1000	-12719.30
XE2222222222	25/5/2001	EUR	+1000	-233.60
XE1111111111	29/5/2001	GBP	-2000	18700.00
XE2222222222	29/5/2001	EUR	+500	-90.00
XG0000000002	29/5/2001	EUR	-1000	17300.00
CASH	4/6/2001	EUR	0	+12.34

im position (derived for initial margin see section 4.3.1)

ISIN	Currency	Net quantity
XE1111111111	EUR	+2123
XE1111111111	GBP	-2000
XE2222222222	EUR	+2500
XE3333333333	EUR	-300
XG0000000001	GBP	-400
XG0000000002	EUR	-1000
XG0000000002	GBP	+160
XG0000000003	GBP	-600
CASH	GBP	0
CASH	EUR	0

Variation Margin Calculation

Date boundary functions	ISIN	ISD	Assume settlement	Currency	Net quantity (Q)	Net consideration (C)	VM price	Price 4.2.2 (P)	Equity VM 4.2.2 (Q*P + C)	By position currency 4.2.3.2	In LCH base currency 4.2.3.3	Total VM 4.2.3.4	
	XE1111111111	23/5/2001		EUR	+123	-1512.90	MID	12.90	73.80	19.20	-73.687456	-580.87	
	XE1111111111	24/5/2001		EUR	+1000	-12300.00	MID	12.90	600.00				
	XE2222222222	24/5/2001		EUR	+1000	-280.00	B/A	0.18	-100.00				
	XE3333333333	24/5/2001		EUR	-300	+36900.40	MID	124.85	-554.60	-87.70			
	XG0000000001	23/5/2001		GBP	+100	-419.25	MID	4.60	40.75				
	XG0000000001	24/5/2001		GBP	-700	+3067.25	MID	4.60	-152.75				
Credit VM restriction	XG0000000002	24/5/2001		GBP	-240	+3024.30	B/A	12.50	24.30				
4.2.3.1	XE1111111111	29/5/2001		GBP	-2000	18700.00	MID	9.414678	-129.356	-734.846			-507.185949
	XG0000000001	25/5/2001		GBP	+200	-881.40	MID	4.60	38.60				
	XG0000000002	25/5/2001		GBP	+400	-5400.00	B/A	12.42	-432.00				
	XG0000000003	25/5/2001		GBP	-600	+299.90	MID	0.52	-12.10				
	CASH	29/5/2001		GBP	0	-199.99	MID	0	-199.99				
	XE1111111111	25/5/2001		EUR	+1000	-12719.30	MID	12.90	180.70	311.94			
	XE2222222222	25/5/2001		EUR	+1000	-233.60	B/A	0.18	-53.60				
	XE2222222222	29/5/2001		EUR	+500	-90.00	B/A	0.18	0.00				
	XG0000000002	29/5/2001		EUR	-1000	+17300.00	B/A	17.1275	172.5				
	CASH	4/6/2001		EUR	0	+12.34	MID	0	12.34				

Price changes calculation for equity of ISIN 'XE1111111111' [4.3.2.1.1]

Days offset [D]	5	4	3	2	1	0
Date	16/5/2001	17/5/2001	18/5/2001	21/5/2001	22/5/2001	23/5/2001
Mid price (EUR)	12.495	12.2	12.31	12.32	12.72	12.9
Mult exchange rate (EUR to GBP)	0.719424	0.714235	0.714286	0.716846	0.735294	0.729820
Mid price (GBP) [P]	8.98920288	8.713667	8.79286066	8.83154272	9.35293968	9.414678
Δ Price (over 2 days) [(P _{D-2} - P _D)/P _D] (to 6 d.p.)	-0.021842	0.013528	0.063697	0.066029		

Base initial margin calculation for bucket 'LIQUID1'

Days offset	5		4		3		2		0
ISIN (Settlement ccy)	Δ Price [Δ P]	Δ Value [Δ P*V] 4.3.2.1.3	Δ Price [Δ P]	Δ Value [Δ P*V] 4.3.2.1.3	Δ Price [Δ P]	Δ Value [Δ P*V] 4.3.2.1.3	Δ Price [Δ P]	Δ Value [Δ P*V] 4.3.2.1.3	Current Value [V] 4.3.2.1.2
XE1111111111 (EUR)	-0.021842	-436.5639476	0.013528	270.3890249	0.063697	1273.134959	0.066029	1319.745485	19987.361394 =2123*12.9*0.72982
XE1111111111 (GBP)	-0.021842	411.270900	0.013528	-254.717548	0.063697	-1199.373863	0.066029	-1243.277888	-18829.356 =-2000*9.414678*1
XG0000000001 (GBP)	-0.083151	152.99784	0.042857	-78.85688	0.050119	-92.21896	0.050228	-92.41952	-1840 =-400*4.6*1
Daily portfolio value change 4.3.2.1.3 Ranking 4.3.2.1.4		127.704686 1		63.191383 2		18.457490 3		15.957582 4	
Base initial margin 4.3.2.1.4	Drop ranking (1), average rankings (2) and (3), and make the result negative = -(63.191383 + 18.457490)/2 = -40.824437								
Portfolio initial margin 4.3.2.1.5	Multiply base initial margin by bucket risk coefficient of 1.25 = -40.824437 * 1.25 = -51.030546								

Final initial margin calculations

Portfolio bucket	Currency	Portfolio initial margin 4.3.2.1	By currency 4.3.2.2	In LCH base currency 4.3.2.3	Total portfolio initial margin 4.3.2.4	Total initial margin 4.3.4
LIQUID1	GBP	-51.030546	-51.030546	-136.823186	-205.23	-3386.21
LIQUID2	EUR	-117.55315	-117.55315			
Flat rate ISIN	Currency	Flat rate initial margin 4.3.3.1	By currency 4.3.3.2	In LCH base currency 4.3.3.3	Total flat rate initial margin 4.3.3.4	
XG0000000002	GBP	-99.68	-130.88	-2120.650009	-3180.98	
XG0000000003	GBP	-31.20				
XE3333333333	EUR	-1872.75	-2726.3846			
XG0000000002	EUR	-853.6346				

6.3 Liquidity & Concentration Margin – OSA only

The fixed parameters used in the calculations are:

HP factor: 0.25
 HP standard: 2
 HP max: 10
 Base ccy: GBP
 EUR to GBP: 1.1

Note: HP is Holding Period

In this example there are only OSA positions. Therefore the 'lm position' and 'lcrm position' datasets are the same. The following table covers both. Four example positions are given showing the following characteristics:

1. LCRM applies - 'HP new' and subsequently the 'LCRM coefficient' are in their acceptable ranges.
2. No LCRM applies - 'HP new' is less than the standard holding period, so is set to 'HP standard' to achieve a zero result.
3. LCRM applies - 'HP new' is limited to its maximum value and subsequently the 'LCRM coefficient' is in its acceptable range.
4. LCRM applies - 'HP new' is limited to its maximum value and subsequently the 'LCRM coefficient' is limited to its maximum value.

Account	ISIN	Currency	Net quantity	Current price	Bucket type	Bucket rate	Daily volume	Current value	HP new initial	HP new final	HP coefficient	LCRM coefficient	LCRM in position ccy	LCRM in base ccy
XXX/C	XF1111111111	EUR	10000	1.20	P	0.05	11000	12000.00	3.6	4	0.414	0.021	-248.53	-225.93
XXX/C	XF2222222222	GBP	10000	1.20	P	0.05	25000	12000.00	1.6	2	0.000	0.000	0.00	0.00
XXX/C	XF3333333333	GBP	10000	1.20	P	0.05	3500	12000.00	11.4	10	1.236	0.062	-741.64	-741.64
XXX/C	XF4444444444	GBP	10000	1.20	F	0.9	3500	12000.00	11.4	10	1.236	1.000	-12000.00	-12000.00

6.4 Liquidity & Concentration Margin – OSA and two ISAs

The fixed parameters used in the calculations are:

HP factor: 0.25
 HP standard: 2
 HP max: 10
 Base ccy: GBP
 EUR to GBP: 1.1

Note: HP is Holding Period

In this example there is an OSA and two ISAs. Therefore the 'lcrm position' dataset is the aggregate of the 'lm position' datasets as shown for one equity below. Four example positions are given in 'lm position' showing the following characteristics:

- Rows 1 & 3 would not have LCRM charged individually but these two long positions aggregated (row 1 of the 'lcrm position' dataset) give rise to an LCRM charge on both of them.
- Row 2 is a single short position which is the same in the two datasets. LCRM arises.
- Row 4 has a separate aggregate for its different position currency. No LCRM arises.

Note that 'HP standard' is carried from the aggregate 'lcrm position' dataset to be used in calculating the LCRM on the 'lm position' dataset.

'lm position' dataset

Account	ISIN	Currency	Net quantity	Current price	Bucket type	Bucket rate	Daily volume	Current value	Match to lcrm row	HP new final	HP coefficient	LCRM coefficient	LCRM in position ccy	LCRM in base ccy
XXX/C	XF2222222222	GBP	10000	1.20	P	0.05	25000	12000.00	1	4	0.414	0.021	-248.53	-248.53
XXX/C/SFID3	XF2222222222	GBP	-27000	1.20	P	0.05	25000	-32400.00	2	5	0.581	0.029	-941.44	-941.44
XXX/C/SFID4	XF2222222222	GBP	12000	1.20	P	0.05	25000	14400.00	1	4	0.414	0.021	-298.23	-298.23
XXX/C/SFID4	XF2222222222	EUR	10000	1.20	P	0.05	25000	12000.00	4	2	0.000	0.000	0.00	0.00
													Total	-1488.20

'lcrm position' dataset [aggregate of the 'lm position' dataset]

Aggregate client positions	ISIN	Currency	Net quantity	Current price	Bucket type	Bucket rate	Daily volume	Current value	HP new initial	HP new final
XXX/C/...	XF2222222222	GBP	22000	1.20	P	0.05	25000	26400.00	3.5	4
XXX/C/...	XF2222222222	GBP	-27000	1.20	P	0.05	25000	-32400.00	4.3	5
XXX/C/...	XF2222222222	EUR	10000	1.20	P	0.05	25000	12000.00	1.6	2

7. EquityClear Service – ERA implementation

The EquityClear service calculates margins using the ERA algorithm as described in this document.

Each time LCH wants to reassess its risk position it will execute a 'margin run', calculating all margins using the latest available positions, prices and ERA parameters.

A margin run will occur once at end-of-day and one or more times intra-day.

EquityClear publishes ERA Risk Parameter files to the LCH.Clearnet website following each margin run for the following datasets [see Section 3 Input Files]:

- Equity²
- Price
- Exchange Rate
- Bucket
- Daily Volume
- Global

The files are comma separated ASCII text and correspond to the dataset definitions provided earlier in the document. They contain a header record of the field names and then zero, one or more detail records. Null fields are represented by a single space. No order of records in the files should be assumed.

Example files are provided in the following section. The content of these files correspond to the IM & VM worked examples.

The following datasets will change very infrequently [see Section 3 Input Files]. The initial values and any changes will be sent to members by circular. Circulars are available on the LCH.Clearnet website.

- LCRM
- LCRM Bucket

Member specific position data will be made available to members in their EquityClear member reports³.

EquityClear calculates the margins for the position accounts under the OSA margin account and provides the results in the EquityClear member reports. It is up to the member whether or how they use this information. The variation margin and initial margin calculations are applied to all the positions in the position account. The wrong way risk calculation and LCRM calculation are only applied to positions where there is wrong way risk margin and LCRM margin arising on equivalent positions in the OSA margin account. That is,

- Wrong way risk is only charged on long positions in the clearing members stock where wrong way risk is charged on the OSA, i.e. the net position on the OSA is also long.
- LCRM is only charged on positions where LCRM has been charged on the same position in the OSA and the direction of the positions are the same.

² Separate equity and corresponding price files may be published for certain sets of derivative instruments

³ These reports are described in the EquityClear Member Reports specifications.

8. Example Parameter Files

The content of these files correspond to the IM & VM worked examples.

8.1 IM & VM for end-of-day 22/5/2001

8.1.1 Global

Current business date, Margin run type, Next LCH business date, CVM date, Counterparty multiplier, LCH base currency, Liquidity Margin Rate

22/5/2001, EOD, 23/5/2001, 24/5/2001, 1, GBP, 0

8.1.2 Equity

ISIN, Name, Currency, Assume settlement, VM price, Bucket code

XE1111111111, IRL BANK, EUR, TRUE, MID, LIQUID1
 XE2222222222, IRL TELECOM, EUR, FALSE, B/A, LIQUID2
 XE3333333333, COMPANIE, EUR, TRUE, MID, FLAT5
 XG0000000001, ABC PLC, GBP, FALSE, MID, LIQUID1
 XG0000000002, DEF PLC, GBP, TRUE, B/A, FLAT5
 XG0000000003, GHI PLC, GBP, TRUE, MID, FLAT10
 CASH, EUR cash only, EUR, TRUE, MID, FLAT0
 CASH, GBP cash only, GBP, TRUE, MID, FLAT0

8.1.3 Price

ISIN, Currency, Date, Bid, Mid, Ask, Price change, Days offset

CASH, EUR, 22/5/2001, , 0, , , 0
 CASH, GBP, 22/5/2001, , 0, , , 0
 XE1111111111, EUR, 22/5/2001, , 12.72, , , 0
 XE1111111111, EUR, 21/5/2001, , 12.32, , , 1
 XE1111111111, EUR, 18/5/2001, , 12.31, , 0.063697, 2
 XE1111111111, EUR, 17/5/2001, , 12.2, , 0.013528, 3
 XE1111111111, EUR, 16/5/2001, , 12.495, , -0.021842, 4
 XE1111111111, EUR, 15/5/2001, , 12.5, , -0.043657, 5
 XE2222222222, EUR, 22/5/2001, 0.235, 0.24, 0.245, , 0
 XE2222222222, EUR, 21/5/2001, 0.26, 0.2775, 0.295, , 1
 XE2222222222, EUR, 18/5/2001, 0.27, 0.285, 0.3, -0.157895, 2
 XE2222222222, EUR, 17/5/2001, 0.225, 0.235, 0.245, 0.180851, 3
 XE2222222222, EUR, 16/5/2001, 0.22, 0.2275, 0.235, 0.252747, 4
 XE2222222222, EUR, 15/5/2001, 0.21, 0.23, 0.25, 0.021739, 5
 XE3333333333, EUR, 22/5/2001, , 123.45, , , 0
 XG0000000001, GBP, 22/5/2001, , 4.4, , , 0
 XG0000000001, GBP, 21/5/2001, , 4.38, , , 1
 XG0000000001, GBP, 18/5/2001, , 4.19, , 0.050119, 2
 XG0000000001, GBP, 17/5/2001, , 4.2, , 0.042857, 3
 XG0000000001, GBP, 16/5/2001, , 4.57, , -0.083151, 4
 XG0000000001, GBP, 15/5/2001, , 4.6, , -0.086957, 5
 XG0000000002, GBP, 22/5/2001, 12.96, 12.99, 13.02, , 0
 XG0000000003, GBP, 22/5/2001, , 0.5, , , 0

8.1.4 Bucket

Bucket code, Price history days, Time horizon, Currency, Discarded portfolio losses, Averaged portfolio losses, Risk coefficient, Bucket type, Risk rate

LIQUID1, 6, 2, GBP, 1, 2, 1.25, P,

LIQUID2, 6, 2, EUR, 2, 1, 1.3, P,

FLAT5, , , , , , F, 0.05

FLAT10, , , , , , F, 0.1

FLAT0, , , , , , F, 0

8.1.5 Exchange rate

From currency, To currency, Date, Mult exchange rate

EUR, GBP, 15/5/2001, 0.728916

EUR, GBP, 16/5/2001, 0.719424

EUR, GBP, 17/5/2001, 0.714235

EUR, GBP, 18/5/2001, 0.714286

EUR, GBP, 21/5/2001, 0.716846

EUR, GBP, 22/5/2001, 0.735294

GBP, EUR, 15/5/2001, 1.371900

GBP, EUR, 16/5/2001, 1.390000

GBP, EUR, 17/5/2001, 1.400100

GBP, EUR, 18/5/2001, 1.400000

GBP, EUR, 21/5/2001, 1.395000

GBP, EUR, 22/5/2001, 1.360000

EUR, EUR, 15/5/2001, 1

EUR, EUR, 16/5/2001, 1

EUR, EUR, 17/5/2001, 1

EUR, EUR, 18/5/2001, 1

EUR, EUR, 21/5/2001, 1

EUR, EUR, 22/5/2001, 1

GBP, GBP, 15/5/2001, 1

GBP, GBP, 16/5/2001, 1

GBP, GBP, 17/5/2001, 1

GBP, GBP, 18/5/2001, 1

GBP, GBP, 21/5/2001, 1

GBP, GBP, 22/5/2001, 1

8.2 IM & VM for intra-day 23/5/2001

8.2.1 Global

Current business date, Margin run type , Next LCH business date, CVM date, Counterparty multiplier, LCH base currency, Liquidity Margin Rate

23/5/2001, ITD, 24/5/2001, 24/5/2001, 1, GBP, 0

8.2.2 Equity

ISIN, Name, Currency, Assume settlement, VM price, Bucket code

XE1111111111, IRL BANK, EUR, TRUE, MID, LIQUID1
 XE1111111111, IRL BANK, GBP, TRUE, MID, LIQUID1
 XE2222222222, IRL TELECOM, EUR, FALSE, B/A, LIQUID2
 XE3333333333, COMPANIE, EUR, TRUE, MID, FLAT5
 XG0000000001, ABC PLC, GBP, FALSE, MID, LIQUID1
 XG0000000002, DEF PLC, EUR, TRUE, B/A, FLAT5
 XG0000000002, DEF PLC, GBP, TRUE, B/A, FLAT5
 XG0000000003, GHI PLC, GBP, TRUE, MID, FLAT10
 CASH, EUR cash only, EUR, TRUE, MID, FLAT0
 CASH, GBP cash only, GBP, TRUE, MID, FLAT0

8.2.3 Price

ISIN, Currency, Date, Bid, Mid, Ask, Price change, Days offset

CASH, EUR, 23/5/2001, , 0, , , 0
 CASH, GBP, 23/5/2001, , 0, , , 0
 XE1111111111, EUR, 23/5/2001, , 12.90, , , 0
 XE1111111111, EUR, 22/5/2001, , 12.72, , , 1
 XE1111111111, EUR, 21/5/2001, , 12.32, , 0.066029, 2
 XE1111111111, EUR, 18/5/2001, , 12.31, , 0.063697, 3
 XE1111111111, EUR, 17/5/2001, , 12.2, , 0.013528, 4
 XE1111111111, EUR, 16/5/2001, , 12.495, , -0.021842, 5
 XE1111111111, GBP, 23/5/2001, , 9.414678, , , 0
 XE1111111111, GBP, 22/5/2001, , 9.35294, , , 1
 XE1111111111, GBP, 21/5/2001, , 8.831543, , 0.066029, 2
 XE1111111111, GBP, 18/5/2001, , 8.792861, , 0.063697, 3
 XE1111111111, GBP, 17/5/2001, , 8.713667, , 0.013528, 4
 XE1111111111, GBP, 16/5/2001, , 8.989203, , -0.021842, 5
 XE2222222222, EUR, 23/5/2001, 0.18, 0.2, 0.22, , 0
 XE2222222222, EUR, 22/5/2001, 0.235, 0.24, 0.245, , 1
 XE2222222222, EUR, 21/5/2001, 0.26, 0.2775, 0.295, -0.279279, 2
 XE2222222222, EUR, 18/5/2001, 0.27, 0.285, 0.3, -0.157895, 3
 XE2222222222, EUR, 17/5/2001, 0.225, 0.235, 0.245, 0.180851, 4
 XE2222222222, EUR, 16/5/2001, 0.22, 0.2275, 0.235, 0.252747, 5
 XE3333333333, EUR, 23/5/2001, , 124.85, , , 0
 XG0000000001, GBP, 23/5/2001, , 4.6, , , 0
 XG0000000001, GBP, 22/5/2001, , 4.4, , , 1
 XG0000000001, GBP, 21/5/2001, , 4.38, , 0.050228, 2
 XG0000000001, GBP, 18/5/2001, , 4.19, , 0.050119, 3
 XG0000000001, GBP, 17/5/2001, , 4.2, , 0.042857, 4
 XG0000000001, GBP, 16/5/2001, , 4.57, , -0.083151, 5
 XG0000000002, EUR, 23/5/2001, 17.017884, 17.072692, 17.1275, , 0
 XG0000000002, GBP, 23/5/2001, 12.42, 12.46, 12.5, , 0
 XG0000000003, GBP, 23/5/2001, , 0.52, , , 0

8.2.4 Bucket

Bucket code, Price history days, Time horizon, Currency, Discarded portfolio losses, Averaged portfolio losses, Risk coefficient, Bucket type, Risk rate

LIQUID1, 6, 2, GBP, 1, 2, 1.25, P,

LIQUID2, 6, 2, EUR, 2, 1, 1.3, P,

FLAT5, , , , , , F, 0.05

FLAT10, , , , , , F, 0.1

FLAT0, , , , , , F, 0

8.2.5 Exchange rate

From currency, To currency, Date, Mult exchange rate

EUR, GBP, 16/5/2001, 0.719424

EUR, GBP, 17/5/2001, 0.714235

EUR, GBP, 18/5/2001, 0.714286

EUR, GBP, 21/5/2001, 0.716846

EUR, GBP, 22/5/2001, 0.735294

EUR, GBP, 23/5/2001, 0.729820

GBP, EUR, 16/5/2001, 1.390000

GBP, EUR, 17/5/2001, 1.400100

GBP, EUR, 18/5/2001, 1.400000

GBP, EUR, 21/5/2001, 1.395000

GBP, EUR, 22/5/2001, 1.360000

GBP, EUR, 23/5/2001, 1.370200

EUR, EUR, 16/5/2001, 1

EUR, EUR, 17/5/2001, 1

EUR, EUR, 18/5/2001, 1

EUR, EUR, 21/5/2001, 1

EUR, EUR, 22/5/2001, 1

EUR, EUR, 23/5/2001, 1

GBP, GBP, 16/5/2001, 1

GBP, GBP, 17/5/2001, 1

GBP, GBP, 18/5/2001, 1

GBP, GBP, 21/5/2001, 1

GBP, GBP, 22/5/2001, 1

GBP, GBP, 23/5/2001, 1